

Cold-Formed Steel-Concrete Beams

Ade Lisantono

Department of Civil Engineering, University of Atma Jaya Yogyakarta
Jln. Babarsari, No. 44, Yogyakarta 55281, E-mail: adelisantono@mail.uajy.ac.id

Haryanto Yoso Wigroho

Department of Civil Engineering, University of Atma Jaya Yogyakarta
Jln. Babarsari, No. 44, Yogyakarta 55281, E-mail: haryanto@mail.uajy.ac.id

Meita Ratna Sari

Alumni, Department of Civil Engineering, University of Atma Jaya Yogyakarta
Jln. Babarsari, No. 44, Yogyakarta 55281, E-mail: metisari@yahoo.com

Abstract

Light weight material usually be chosen as a material for earthquake resistant building in order to reduce inertia force of the building. In comparison with others section, a cold-formed steel section is a lighter section and makes this section is categorized as a light weight material. During reconstruction of Yogyakarta earthquake of 27th May 2006 some housings were constructed by using cold-formed steel sections. However, investigation on the utility of cold-formed steel section for structural elements was very limited. Two experimental programs of cold-formed steel-concrete beams were carried out. One of the experiment used normal weight concrete and the other used light weight concrete. In the experimental programs, the normal weight concrete had the compressive strength of 23.53 MPa, while the light weight concrete had the compressive strength of 12.91 MPa. This paper tried to analyze and compare those experimental programs. The comparison showed that the cold-formed steel beam with normal weight concrete gave higher load capacity than the cold-formed steel beam with light weight concrete. However, if the comparison was taken with respect to the ratio of compressive strength to density, the cold-formed steel beam with light weight concrete might give more promising bending elements for earthquake resistant building.

Keywords: *Cold-formed steel-concrete beams, normal weight concrete, light weight concrete, load capacity, comparison.*

Abstrak

Bahan yang ringan biasanya dipilih sebagai bahan untuk bangunan tahan gempa, dengan tujuan untuk mengurangi gaya inersia akibat gempa pada bangunan tersebut. Dibandingkan dengan profil lainnya, profil baja dengan bentukan-dingin merupakan profil yang lebih ringan sehingga membuat profil ini dapat dikategorikan sebagai bahan yang ringan. Pada rekonstruksi rumah-rumah akibat gempa Yogyakarta tanggal 27 Mei 2006, beberapa diantaranya dibuat dengan menggunakan profil yang ringan yaitu profil baja bentukan-dingin sebagai elemen strukturnya. Meski banyak digunakan sebagai elemen struktur, tetapi penelitian elemen struktur yang menggunakan profil baja bentukan-dingin sangatlah terbatas. Dua program eksperimen balok yang menggunakan profil baja bentukan-dingin dengan pengisi beton telah dilakukan. Yang satu menggunakan pengisi beton normal dan yang lainnya menggunakan pengisi beton ringan. Pada program eksperimen tersebut, beton normal yang dipakai mempunyai kuat tekan 23,53 MPa, sedangkan beton ringan mempunyai kuat tekan 12,91 MPa. Makalah ini mencoba untuk menganalisis serta membandingkan kedua program eksperimen tersebut. Hasil perbandingan menunjukkan bahwa balok profil baja bentukan-dingin yang berpengisi beton normal memberikan kapasitas beban yang lebih tinggi dari pada balok profil baja bentukan-dingin yang berpengisi beton ringan. Akan tetapi apabila perbandingan didasarkan pada rasio kuat tekan terhadap berat jenisnya, maka balok profil baja bentukan-dingin dengan pengisi beton ringan merupakan elemen lentur yang lebih menjanjikan untuk digunakan sebagai elemen struktur pada bangunan tahan gempa.

Kata-kata Kunci: *Balok profil baja bentukan-dingin berpengisi beton, beton normal, beton ringan, kapasitas beban, perbandingan*

1. Introduction

In order to reduce inertia force of building due to earthquake force, it is often to replace the heavier material of building with the lighter material. There are some light materials such as light weight concrete, light steel and wood which are generally chosen for earthquake resistant building materials.

During reconstruction after earthquake of 27th May 2006 in Yogyakarta, some houses were built using light material such as light steel, light weight concrete, wood and bamboos. Nowadays, the utility of light steel such as cold-formed steel section is not only for purlin but also for main structures of the building. Wuryanti (2005) carried out an experimental program to test four types of steel frames made of cold-formed steel sections. Type 1 was open frame, type 2 was frame with bracing, type 3 was infill frame, in which the brick was not tied to the frame, and type 4 was infill frame, in which the brick was tied to the frame. The test showed that type 4 is more ductile compared to the others.

The cold-formed steel section has large ratio of width to thickness. Due to the high ratio of width to thickness and unsymmetrical centroidal axis in the section made the cold-formed steel section becomes unstable and may buckle in different modes and with mode interaction (Bambach, 2010). Rossi et al. (2010) investigated how the different formulations account for the two buckling modes and their interaction of the cold-formed stainless steel sections. Because of the properties of the cold-formed steel section that is easily to buckle, some researchers tried to make this shape becomes stiffer and applicable for structural elements of building.

Sinaga (2005) made an experimental program of single cold-formed steel section as a beam by adding stiffeners. The stiffeners were made of the reinforcement bars and welded vertically connecting between the edges of the stiffened flanges. The result showed that the capacity of the beam increased between 69.26 % and 153.34%, depending on the spacing of the stiffeners.

Wigroho in 2008 carried out an experimental study on the capacity of cold-formed steel beams with stiffeners and filled with normal weight concrete. The result showed that the capacity of the beam increased 2.46 times compared to the beam without concrete.

Lisantonno and Sari (2009) carried out the experiment similar to Wigroho (2008) but Lisantonno and Sari (2009) used light weight concrete as the filler of the experimental program showed that the capacity of the beam increased 1.84 times compared to the beam without concrete.

In order to see the advantages of the experimental programs carried out by Wigroho (2008) and by Lisantonno and Sari (2009), this paper tried to analyze and compare of both experimental programs.

2. Cold-Formed Steel Section

Cold-formed structural steel sections were produced by passing sheet or strip steel at room temperature through rolls or press brakes and then bending the steel into desired shape (Vinnakota, 2006). Lipped channel steel section is one of the cold-formed steel section that has lighter weight compared to other steel section.

The cold form process of the lipped channel section made the properties of this section was change, and usually the yield stress of the material was increase (Tall, 1974).

Figure 1 shows the Diamond Penetration Number of the lipped channel section due to cold form effect, where the value shows the increasing of the yield stress.

3. Experimental Program

3.1 Materials

The size of lipped channel steel section used in the both experiments were the height = 93,2 mm, the width = 34,9 mm, the thickness = 2,06 mm. Wigroho (2008) used the lipped channel steel-concrete beams with normal weight concrete. Lisantonno and Sari (2009) used the lipped channel steel-concrete beams with light weight concrete, where the coarse aggregates of the light weight concrete made of autoclaved aerated concrete brick.

3.2 Stiffener of lipped channel section

The lipped channel steel-concrete beams in the both experiments were using stiffeners where the stiffener was made of the reinforcement bar with the diameter of 6 mm. The stiffeners were welded vertically between the edges of stiffened flanges (**Figure 2**). Three types spacing of stiffeners were made in these experiments, there were 150 mm; 200 mm; and 300 mm as shown in **Figure 3**

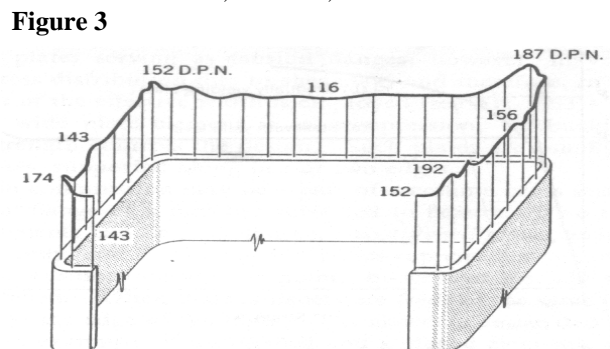

Figure 1. Diamond penetration number of the cold-formed steel section (Tall, 1974)

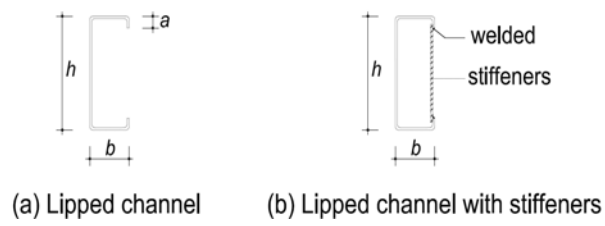

Figure 2. Vertically stiffener

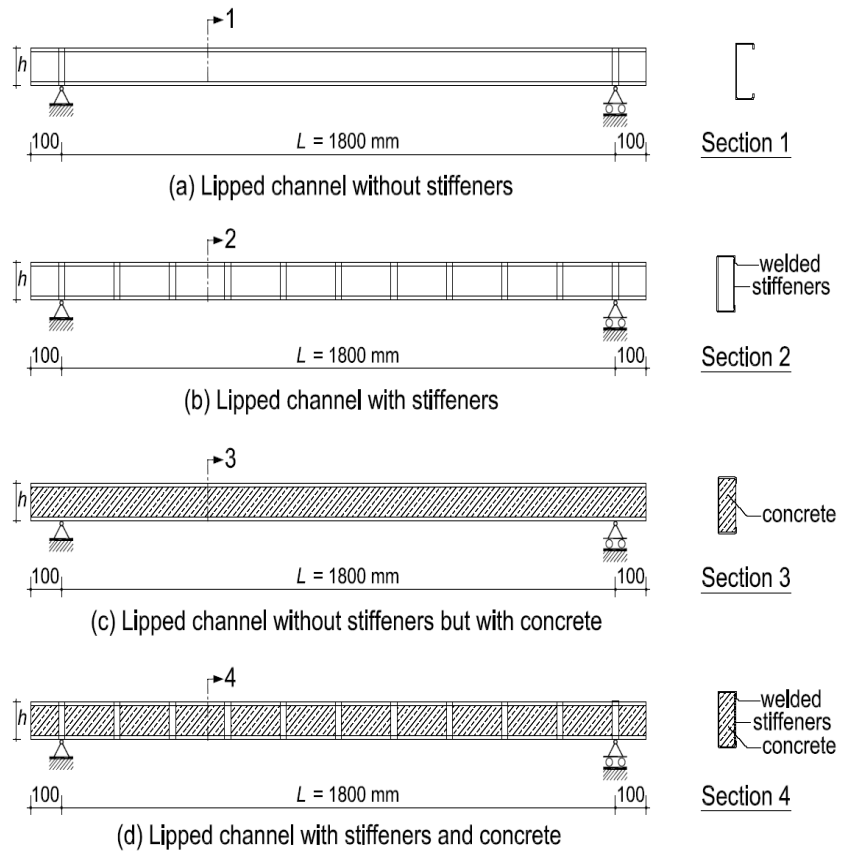

Figure 3. Spacing of stiffeners

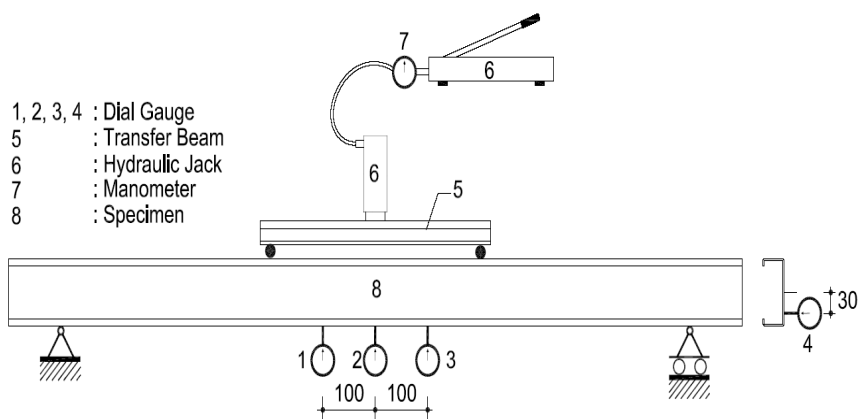

Figure 4. Setup testing of specimen

3.3 Setup of testing

Specimens of lipped channel steel-concrete beam were tested on the loading frame. The specimens were loaded with two-point load by using hydraulic jack, through a transfer beam as depicted in **Figure 4**

The beam was simple beam with span of the beam from support to support was 1800 mm. The transfer beam had span 600 mm and the support of the transfer beam were located 600 mm from the support of the main beam. Three dial gauges were used to measure deflection of the beam. One dial gauge was located at the middle of the beam and two others were located at 100 mm from the middle (see **Figure 4**).

Acquisition data of the load and the deflection of the beams was taken in every period of loading. The loading was stopped for temporary and was held to give a chance to get the data.

4. Result and Discussion

4.1 Concrete material

The average compressive strength of normal weight concrete tested from cylinder specimen (150 mm x 300 mm) at 28 days was 23.53 MPa with average density = 2271.27 kg/m³. While the average compressive strength of lightweight concrete at same days was 12.91 MPa, average density = 1549.95 kg/m³ and average of modulus elasticity = 9685.13 MPa.

4.2 Steel material

Yield stress of the steel was taken from the sample with the size of thickness = 1.98 mm, width = 24.79 mm and length = 107.8 mm. The yield stress of the lipped chan-

nel steel section was 284.578 MPa with tensile strength = 355.723 MPa. According to SNI 03-1729-2002 the steel was categorized as BJ-34 with minimum tensile strength = 340 MPa and yield stress = 210 MPa. The modulus of elasticity of this steel = 202,249.10 MPa.

4.3 Testing of the beams

4.3.1 Lipped channel steel beam without concrete

In order to investigate the effect of stiffener spacing of the lipped channel steel beam without concrete, there were four lipped channel steel beams tested by Wigroho in 2008. One beam was made without stiffener (S0), and the others were made using stiffeners with the stiffener spacing of 150 mm (S15), 200 mm (S20) and 300 mm (S30). The load vs deflection relationship of the lipped channel steel beams without concrete can be seen in **Figure 5**.

Figure 5 shows that the lipped channel steel beams without concrete with several types of stiffener spacing gave almost the same strength (see also **Table 1**). It indicated that there is no significant effect of the stiffener spacing to the capacity of the lipped channel steel beam without concrete.

Table 1. Maximum load of the lipped channel steel beam without concrete

Beam	Load (kg)
S0	207.66
S15	210.43
S20	207.66
S30	207.66

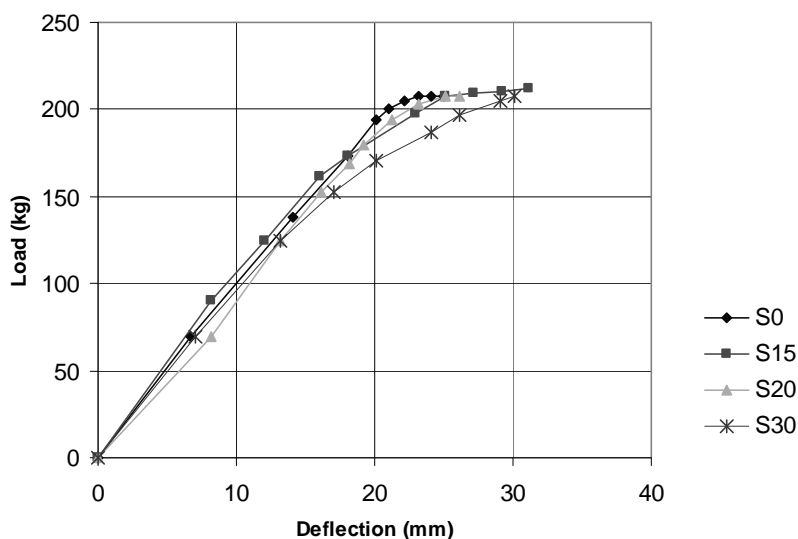

Figure 5. The lipped channel steel beams without concrete (Wigroho, 2008)

4.3.2 Lipped channel steel beam with normal weight concrete

The load vs deflection relationship of the lipped channel steel beams with normal weight concrete can be seen in **Figure 6**. While the load capacity of the lipped channel steel beam with normal weight concrete can be seen in **Table 2**.

Figure 6 and **Table 2** show that the lipped channel steel-concrete beam with stiffener spacing of 200 mm (SC20) gave the largest capacity compared to others beam (SC0; SC15; and SC30).

Based on comparison between the lipped channel steel beam without normal weight concrete and with normal weight concrete shows that the filler of normal weight concrete increases the load capacity of the beam (**Table 3**).

Table 3 shows that the filler of normal concrete increases the load capacity of the lipped channel steel beam with the ratio of increment are 2.53; 2.59; 2.67; and 2.53 for SC0; SC15; SC20; and SC30, respectively.

4.3.3 Lipped channel steel beam with light weight concrete

The load vs deflection relationship of the lipped channel steel beams with light weight concrete can be seen in **Figure 7**.

It can be seen from **Figure 7** and **Table 4** that among the lipped channel steel beams with light weight concrete, the beam with stiffener spacing of 200 mm has the largest load capacity.

Table 2. Maximum load of the lipped channel steel beams with normal weight concrete

Beam	Load (kg)
SC0	526.07
SC15	546.84
SC20	553.76
SC30	526.07

Table 3. Comparison maximum load of the lipped channel steel beams without and with normal weight concrete

Beam	Without concrete	With normal weight concrete
	Load (kg)	Load (kg)
SC0	207.66	526.07
SC15	210.43	546.84
SC20	207.66	553.76
SC30	207.66	526.07

Table 4. Maximum load of the lipped channel steel beams with light weight concrete

Beam	Load (kg)
SCL15	449.93
SCL20	484.54
SCL30	380.71

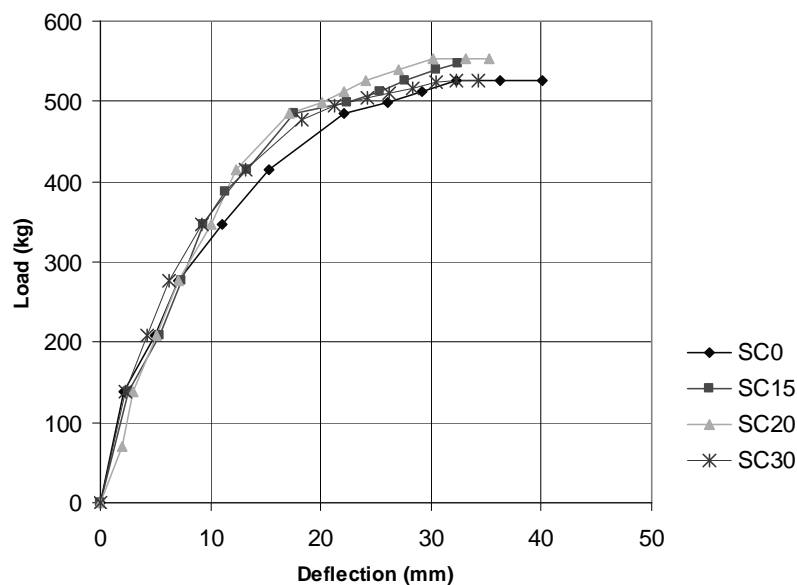

Figure 6. The beams with normal weight concrete

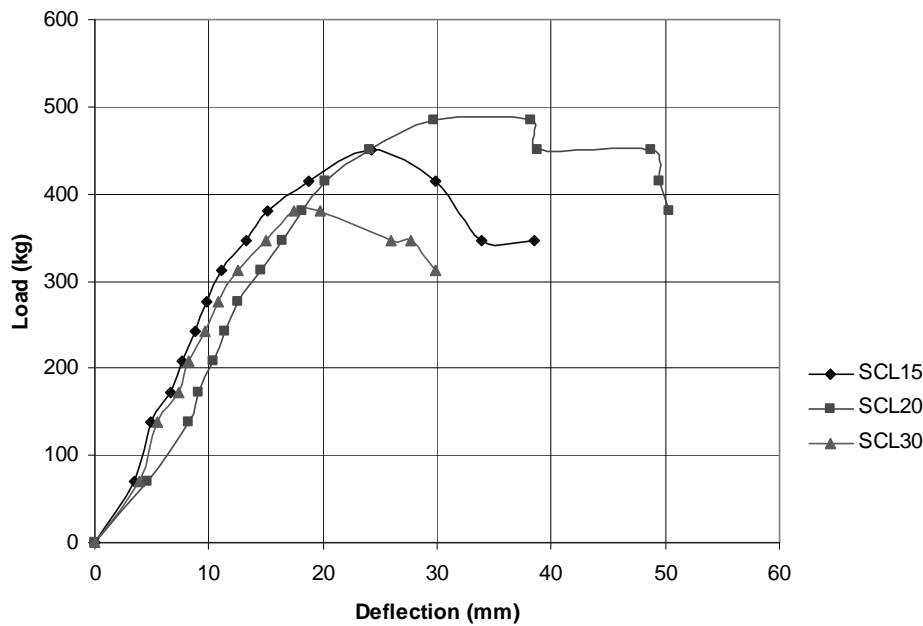

Figure 7. The beams with light weight concrete

Table 5. Comparison maximum load of the lipped channel steel beams without and with light weight concrete

Beam	Without concrete Load (kg)	With light weight concrete Load (kg)
SCL15	210.43	449.93
SCL20	207.66	484.54
SCL30	207.66	380.71

Based on comparison between the lipped channel steel beam without light weight concrete and with light weight concrete shows that the filler of light weight concrete also increases the load capacity of the beam (Table 5).

It can be seen from Table 5 that the filler of light weight concrete increases the load capacity of the lipped channel steel beams with the ratio of increment are 2.14; 2.33; and 1.83 for SCL15; SCL20; and SCL30, respectively.

4.3.4 Comparison between the lipped channel steel beams with normal weight concrete and with light weight concrete

According to the results testing of the lipped channel steel beams with normal weight concrete and lipped channel steel beams with light weight concrete show that the maximum load of the lipped channel steel beam with filler of normal weight concrete and the lipped channel steel beam with filler of light weight concrete are obtained by the lipped channel steel-concrete beam with stiffener spacing of 200 mm (Table 3 and Table 4).

According to the ratio of increment for the beams with stiffener spacing of 200 mm, it can be seen that the beam with normal concrete gives ratio of increment 2.67 while the beam with light weight concrete gives ratio of increment 2.33. The differences of those ratio of increments due to the compressive strength of the normal concrete and the light weight concrete is different. The normal concrete has the compressive strength $f_c' = 23.53$ MPa, while the light weight concrete has the compressive strength $f_c' = 12.91$ MPa.

When the comparison is taken with respect to the elastic bending stress, the following discussions can be drawn:

(i) Steel shape without concrete:

The equation of bending stress for steel shape can be written as

$$f_b = \frac{M}{W} \quad (1)$$

Where,

f_b = bending stress of steel at the bottom fiber

M = bending moment

W = bending moment

(ii) Steel shape with concrete:

According to Gere dan Timoshenko (1991) that the bending stress of composite section can be determined by following equation:

$$f_b = \frac{MyE_s}{E_s I_s + E_c I_c} \quad (2)$$

Where,

f_b = bending stress of steel at the bottom fiber

M = bending moment

y = perpendicular distance from the neutral axis to a point

E_s = the modulus of elasticity of steel

E_c = the modulus of elasticity of concrete

I_s = the moment of inertia of steel

I_c = the moment of inertia of concrete

Based on **Equation (1)** and **(2)**, Wigroho (2008) stated that the lipped channel steel beam with filler of normal weight concrete can increase the bending stress 2.46 times compared to the beam without the filler. While Lisantono and Sari in 2009 stated that the lipped channel steel beam with the filler of light weight concrete can increase the bending stress 1.84 times compared to the beam without the filler. It can be seen that the beams with normal weight concrete have good performance in increasing of bending stress, this due to the compressive strength and modulus of elasticity of normal weight concrete are higher than light weight concrete.

However, when the comparison is taken with respect to the ratio of compressive strength to average density, it can be seen that the ratio of compressive strength to average density of normal concrete and light weight concrete are 0.010 and 0.008, respectively. It can be seen also that if the compressive strength of light weight concrete had the same strength with the normal concrete, so the ratio of compressive strength to average density of light weight concrete becomes 0.015. This value is larger than the ratio of the compressive strength to the average density of normal concrete (0.010). It indicates that if the compressive strength of the light weight concrete can be increased up to the compressive strength of normal concrete (i.e. high strength concrete using artificial light weight aggregates), the lipped channel steel beam with filler of light weight concrete gives more promising bending element for the earthquake resistant building.

5. Conclusions

Based on the discussion above, the following conclusions can be drawn:

1. Comparing among the lipped channel steel-concrete beams with various spacing of stiffeners showed that the beam with stiffener spacing of 200 mm gave the maximum load capacity for both

beams whether with the filler of normal weight concrete or of light weight concrete.

2. Based on the increment ratio of load capacity between the lipped channel steel beams without concrete and with concrete, it can be seen that the lipped channel steel beam with the filler of normal weight concrete gave ratio of increment 2.67, while the lipped channel steel beam with the filler of light weight concrete gave ratio of increment 1.83. The difference of this increment ratio was due to different values of compressive strength and modulus of elasticity between normal and light weight concretes. It also caused the bending stress of lipped channel beams with the filler of normal weight concrete had a good performance compared to lipped channel beams with the filler of light weight concrete.
3. When the comparison was taken with respect to the ratio of compressive strength to average density, it could be seen that the ratio of compressive strength to average density of normal concrete and light weight concrete were 0.010 and 0.008, respectively. If the compressive strength of light weight concrete had the same compressive strength as the normal concrete, it could be seen also that the ratio of compressive strength to average density of the light weight concrete became 0.015. It indicated that if the light weight concrete had the same compressive strength as the normal weight concrete, the lipped channel steel beam with the filler of light weight concrete might give more promising bending element for the earthquake resistant building.

6. Acknowledgment

These experimental programs were carried out in the Laboratory of Structures and Materials, Department of Civil Engineering, Faculty of Engineering, University of Atma Jaya Yogyakarta. The authors would like to thanks to the Laboratory of Structures and Materials for the use of their research facilities.

References

- Bambach, M.R., 2010, Unified Element and Section Approach to Design of Cold-Formed Steel Structures, *Journal of Structural Engineering*, ASCE, Vol. 136, No. 4, April, 343-353.
- Gere, J.M., Timoshenko, S.P., 1991, *Mechanics of Materials*, London: Third Edition SI Version, Chapman & Hall,
- Lisantono, A. and Sari, M.R., 2009, Kuat Lentur Profil Lipped Channel Berpengaku dengan Pengisi Beton Ringan Beragregat Kasar Autoclaved

Aerated Concrete Hebel, Jakarta: *Proceeding of The 3rd Konferensi Nasional Teknik Sipil* (Konteks 3), 6-7 May, Universitas Pelita Harapan, S.99-S.105.

- Rossi, B., Jaspart, J.P. and Rasmussen, K.J.R., 2010, Combined Distortional and Overall Flexural-Torsional Buckling of Cold-Formed Stainless Steel Sections: Experimental Investigations, *Journal of Structural Engineering, ASCE*, Vol. 136, No. 4, April, 354-360.
- Sinaga, R.M., 2005, *Perilaku Lentur Baja Profil C Tunggal dengan Menggunakan Perkuatan Tulangan Arah Vertikal*, Final Project, Civil Engineering Department, Faculty of Engineering, Universitas Atma Jaya Yogyakarta.
- Tall, L., 1974, *Structural Steel Design*, New York: John Wiley & Sons. Inc.
- Wigroho, H.Y., 2008, Kuat Lentur Profil C Tunggal dengan Perkuatan Tulangan Vertikal dan Cor Beton Pengisi, *Journal of Civil Engineering, Civil Engineering Department, Faculty of Engineering, Universitas Atma Jaya Yogyakarta*, ISSN 1411-660X, Volume 8, Number 3, Juni, 264-277.
- Wuryanti, W., 2005, Penggunaan Baja Cold-Form Sebagai Struktur Utama Konstruksi Rumah Tahan Gempa, *Journal of Civil Engineering*, ISSN 1693-4652, Volume 3, Number 1, April, 37-49.
- Vinnakota, S., 2006, *Steel Structures : Behavior and LRFD*, McGraw-Hill International Editon, Singapore.